

USER'S MANUAL

PowerMust 636 (600VA) Offline, Schuko

PowerMust 848 (800VA) Offline, Schuko



Uninterruptible Power Supply

EN

IMPORTANT SAFETY INSTRUCTIONS SAVE THESE INSTRUCTIONS

CAUTION!!

Please read the following information carefully and save this manual for further reference. Disregard of these safety notes may endanger life or health, as well as the function of the equipment and the safety of your data.

- Risk of Electric Shock Heatsinks are live. Disconnect unit before servicing.
- Risk of Electric Shock. This unit receives power from more than one source. Disconnection of AC sources and the DC source is required to de-energize this unit before servicing.
- Risk of Electric Shock. Hazardous live parts inside this unit are energized from the battery supply even when the input AC power is disconnected.
- Risk of Electric Shock. Do not remove cover. No user serviceable parts inside. Refer servicing to qualified service personnel.
- To reduce the risk of fire, replace only with same type of fuse. Refer servicing to qualified service personnel only.
- The sum of the leakage current of the UPS and the connected equipment should not exceed 3.5mA.
- Do not dispose of batteries in a fire as they may explode.
- Do not open or mutilate the battery or batteries. Released electrolytes are harmful to the skin and eyes. It may be toxic.
- A battery can present a risk of electric shock and of having a high short circuit current. The following precaution should be observed when working on batteries:
 - 1) Remove watches, rings or other metal objects from the handles.
 - 2) Use tools with insulated handles.
 - 3) Wear rubber gloves and boots.
 - 4) Do not lay tools or metal parts on top of batteries.
 - 5) Disconnect charging source prior to connecting or disconnecting batteries terminal.

- To replace the batteries by qualified service personnel. Use the same number and type of sealed lead-acid batteries.
- This pluggable type A equipment with battery already installed by the supplier is operator installable and may be operated by laymen.
- The mains socket outlet that supplies the UPS shall be installed near the UPS and shall be easily accessible.
- Sealed, lead-acid, 6 cells battery.
- ϕ on the rating label stands for phase symbol.
- The maximum ambient temperature rating is 40°C.

WARNING!!

- Refer servicing to qualified service personnel only.
- To reduce the risk of fire or electric shock, install in a temperature and humidity controlled indoor area free of conductive contaminants.
- Risk of Electric Shock. Battery circuit is not isolated from AC input, hazardous voltage may exist between battery terminals and ground. Test before touching.

System Description

Top --

- 1. Power On/Off Switch
- 2. Green LED : AC Mode/Battery mode
- 3. Red LED: Fault LED
- 4. All receptacles are surge protected
- 5. Surge protection receptacles
- 6. Battery power supplied receptacles

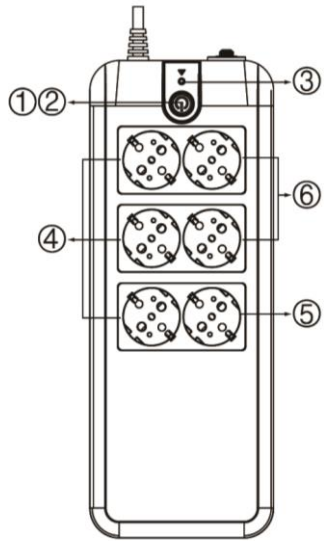

Side --

- 7. AC Input
- 8. Breaker
- 9. Modem/Phone Line Surge Protection

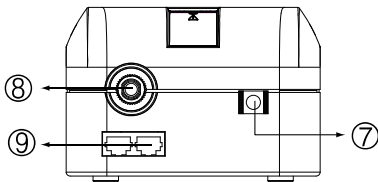

PowerMust 636 (600VA)
Offline, Schuko

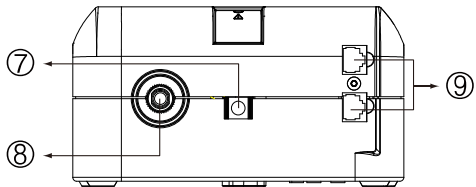

PowerMust 848 (800VA)
Offline, Schuko

Installation & Operation

Installing the New office UPS is as easy as following the steps shown. Be aware that the Power Switch must be kept in the “ON” position and all equipment must be plugged into the Battery Power Supplied Receptacles, otherwise, the UPS will be disabled and your equipment will not be protected during a power failure.

1. Inspection

Remove the UPS from its packaging and inspect it for damage that may have occurred during shipping. If any damage is discovered, repack the unit and return it to the place of purchase.

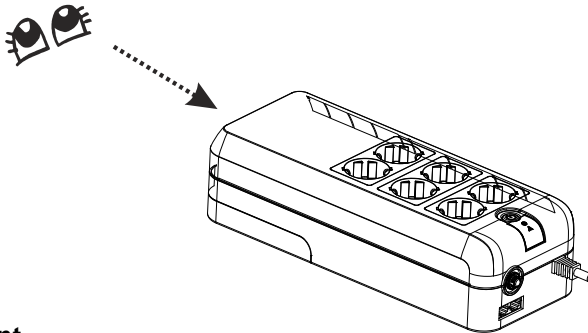

2. Placement

Install the UPS unit in any protected environment that provides adequate airflow around the unit, and is free from excessive dust, corrosive fumes and conductive contaminants. DO NOT operate your UPS in an environment where the ambient temperature or humidity is high.



3. Charging

This unit is shipped from the factory with its internal battery fully charged. However, some energy may be lost during shipping, so the battery should be recharged before using it. Plug the unit into an appropriate power supply, then switch on UPS and allow the UPS to charge fully by leaving it plugged in for at least 8-10 hours with no load (no electrical devices such as computers, monitors, etc.) connected.

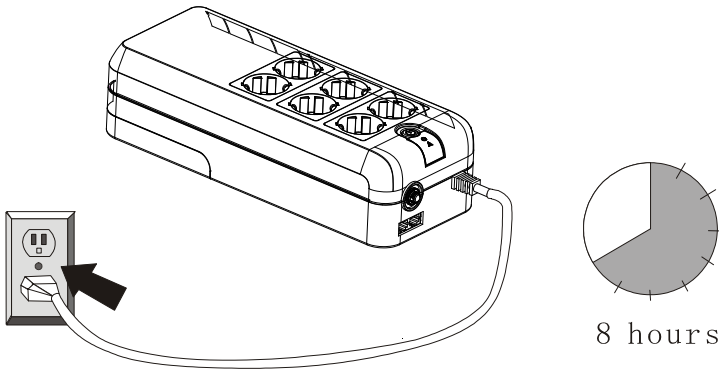

4. Computer Connection

Connect one computer-related device into one of the battery supplied receptacles on the top of UPS. New office UPS provides six receptacles, all for surge protection, four plus battery backup.

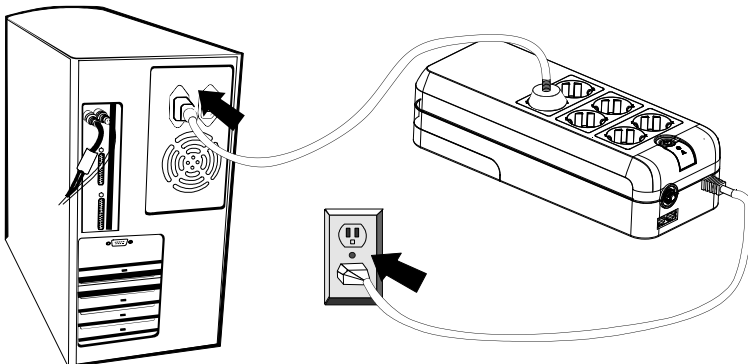

5. Peripheral Equipment Connection

Plug your peripheral equipment (printer, scanners, speakers) into the full-time surge protection outlets. These receptacles do not provide any power during a power failure.

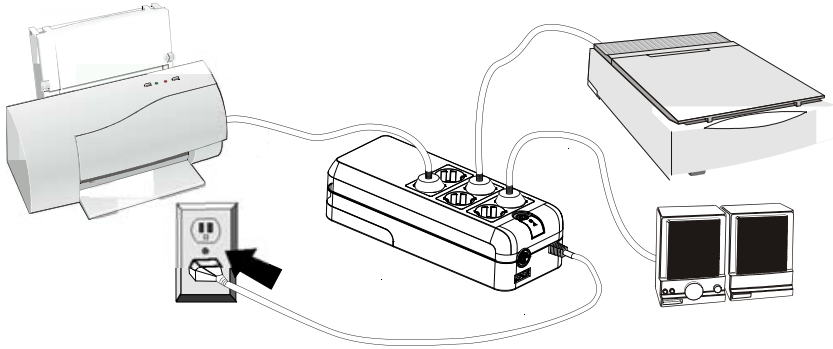

Note: DO NOT plug a laser printer, copier, space heater, vacuum or other large electrical device into the UPS. The power demands of these devices will overload and possibly damage the unit.

6. Modem/Phoneline Connection

Plug incoming internet line into the "In" socket at the side panel of the UPS. Use one more internet line cable and plug one end of the internet line cable to the "Out" socket at the side panel of the UPS. Plug the other end of the modem input socket as shown.

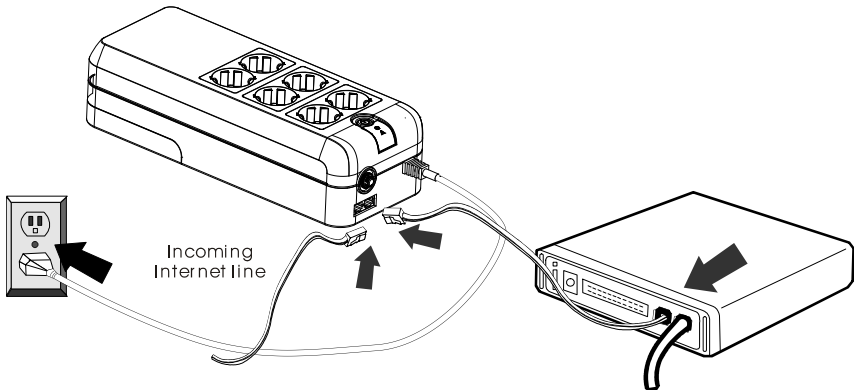

7. Circuit Breaker

When short circuit happens, the circuit breaker will pop-up and then the UPS will shutdown automatically. After waiting for 2 minutes, please press the circuit breaker button again and the mains (AC power) will comeback.

8. Turn On/Off

Press power switch 2 seconds to turn on the UPS.

Press power switch again to turn off the UPS.

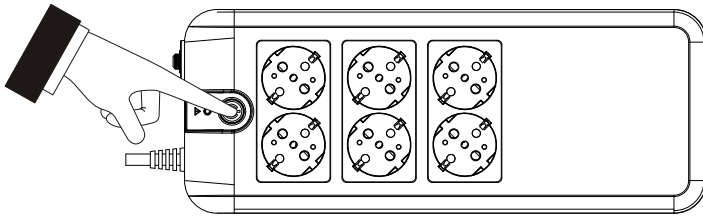

9. DC Start Function

DC Start Function enables UPS to be started up when AC utility power is not available and battery is fully charged. Just simply press the power switch to turn on the UPS.

10. Battery Replacement

CAUTION:

Battery replacement should be performed by qualified service personnel. Please follow the charts below to replace the batteries.

Step 1: Please prize up the battery cover gently.

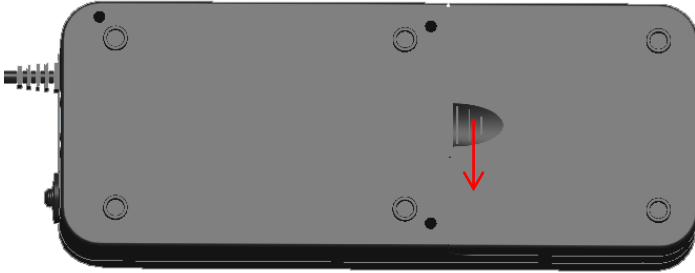

Chart 1

Step 2: Please remove the battery cover gently.

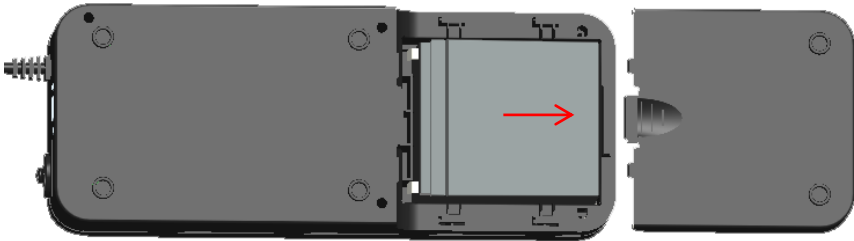

Chart 2

Step3: After removing battery cover, gently extract the battery by disconnecting the two wires connecting to the UPS. Be sure to replace the same type of batteries and dispose of old batteries properly at an appropriate recycling facility.

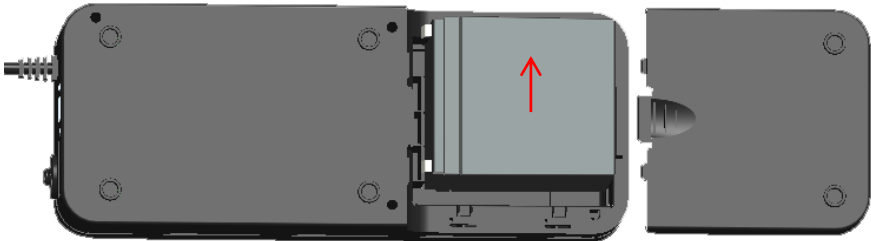

Chart 3

Specification

POWER RATING	PowerMust 636 (600VA) Offline, Schuko	PowerMust 848 (800VA) Offline, Schuko
INPUT	Sine	
Range of Input Voltage	170Vac~270Vac	
Nominal Voltage	220Vac	
Nominal Frequency	50H/60HZ	
OUTPUT		
Line Mode	Same as input	
Battery Mode	Step wave	
Line Mode Voltage	Same as input voltage	
Battery Mode Voltage	220Vac±10%	
Line Mode Frequency	Same as input frequency	
Battery Mode Frequency	50Hz/60Hz ±1Hz	
Transfer time	2-8ms typical ,12ms Max	
BATTERY		
Battery type	600VA	800VA
	12V/5Ah*1	12V/7Ah*1
Backup time	100W SPS LOAD	
	17mins	20mins
Recharge time	10 hours max. (Recharge to 90% Capacity)	
DISPLAY		
Condition	Green Led	Red Led
Line mode normal	Lighting	Off
Battery normal	Lighting per 5s	Off
Battery low	Lighting per 1s	Lighting
Fault	Off	Lighting
Over load(battery mode)	Lighting per 1s	Lighting
AUDIBLE ALARM		

Condition	Buzzer	
Battery normal	Buzzing Per 5s	
Battery low	Buzzing Per 1s	
Fault	Continuous sounding	
Over load	Buzzing Per 0.5s	
PROTECTION	TVSS / Over load / Short Circuit Protection/Over charge	
PHYSICAL	600VA	800VA
Dimension (DxWxH)	320*125*86(mm)	335*170*92.5(mm)
Net Weight	3.1KG	4.1KG
Outlets	Schuko type	
	6 outlets (2 for surge only, 4 for battery backup)	
ENVIRONMENT	Operation Temperature	Operation Humidity
	0-40℃	0%-85%

Trouble Shooting

If the UPS failed to operate properly, please review the following points firstly.

